

# Z Series Impact Hammer Dimensions

Air-Hydraulics, Inc.

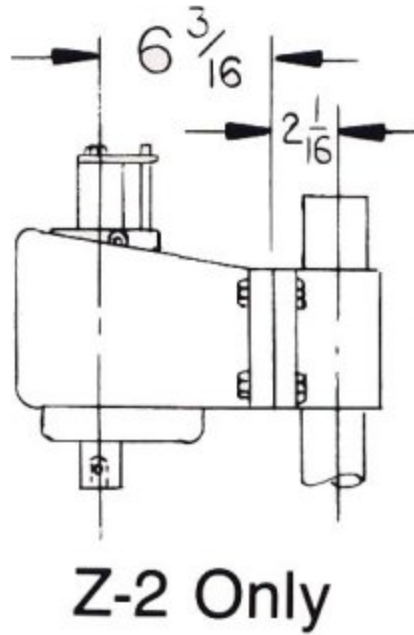
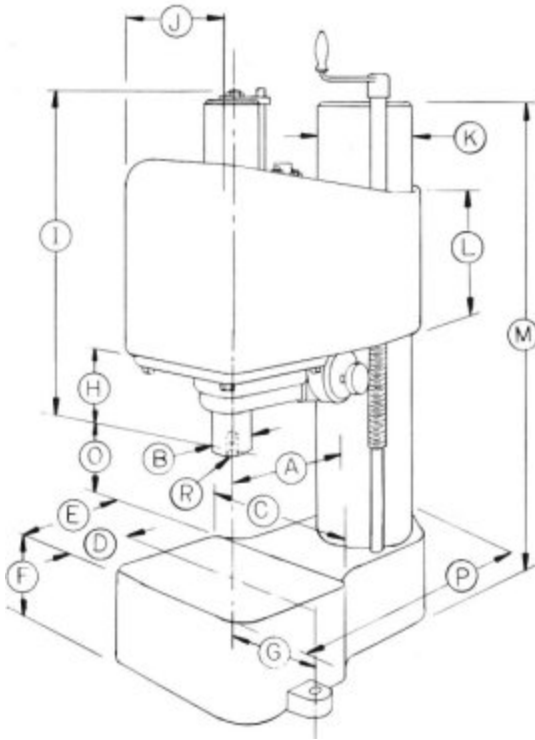

(U.S. Inches)																			
Model	A	B	C	D	E	F	G	H	I	J	K	L	M	N	O	P	R	S	T
Z-2	6-25/32	1-1/2	10	3-1/4	8-3/4	3-7/8	5-5/8	5	19	7	2-15/16	9-1/8	26	3/8	8	19-3/4	9/16	3	6
Z-6	8	2-1/4	11	4	8	5	6-1/2	5	20-5/8	9-1/4	5-15/16	9	34	1/2	15	14-1/2	7/8	4	20

R = Hole in End of Ram  
 T = Max. Tons Impact  
 S = Stroke for Best Results  
 N = Connecting Pipe Size